



Soft&Go

PLUS

Single flavour counter top machine to produce soft gelato and yogurt gelato.

Equipped with peristaltic pump, it is easy and fast to maintain

A compact machine

Perfect for all shops that have limited space. Even in restaurants and in coffee shops it is now possible to taste a delicious gelato and frozen yogurt

Efficient

It produces excellent cream gelatos and fruit sorbets together with a very good frozen yogurt



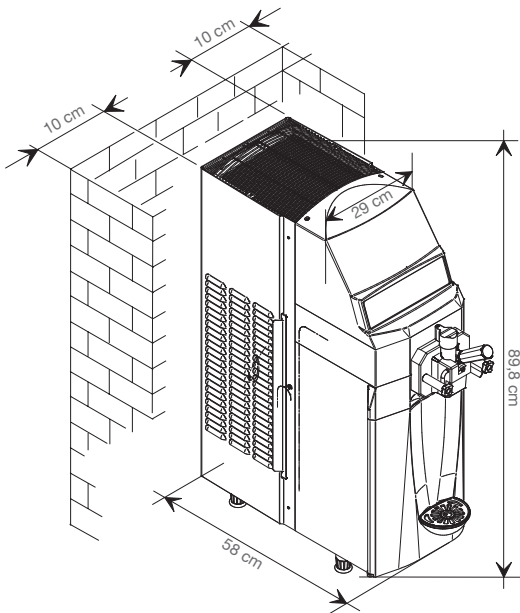

Optional configurations



Teorema Remote Control

It gives very important info about the machine, it facilitates the service system and helps the cleaning schedule



Single portions dispensing head

With interchangeable nozzles to make single portions and delights



Self closing device

The dispenser closes automatically stopping the flow of ice cream, eliminating any waste and preventing mess

	Flavours	Pump	Hourly production (70gr portions)	Tank Capacity lt	Nominal Power kW	Fuse Size A	Power Supply	Cooling System	Refrigerant	Net Weight kg
Soft&Go PLUS	1	Peristaltic	180*	5	1,8	16	230/50/1**	Air	R404	88

* production capacity depends on the mix used and the room temperature

** other voltages and cycles available upon request

Features

Benefits

Able to work with "bag in box" system	Possibility to feed the cylinder directly from the original mix container (5 lt max bag in box system)
Multifunction panel	Soft & go will inform you about: mix temperature, consistency, status of the product and status of the mix in the hopper
Visual alarm	Alarms for: mix is missing, wrong mix filling, cabinet door open, cabinet defrost needed and machine cleaning
Front cabinet	It has automatic defrost system, it is ventilated and cooled
Air cooled	Vertical ventilation with side intake and top air coming out
Front mix filling	Very easy mix filling directly from the front of the machine. All you need to do is open the door cabinet and pour the mix in the bowl
Defrost system	Possibility to heat the cylinders to simplify the cleaning procedure
Overrun adjustment directly from the display	It allows the operator to modify the overrun in a very easy way, directly from the front control display panel